

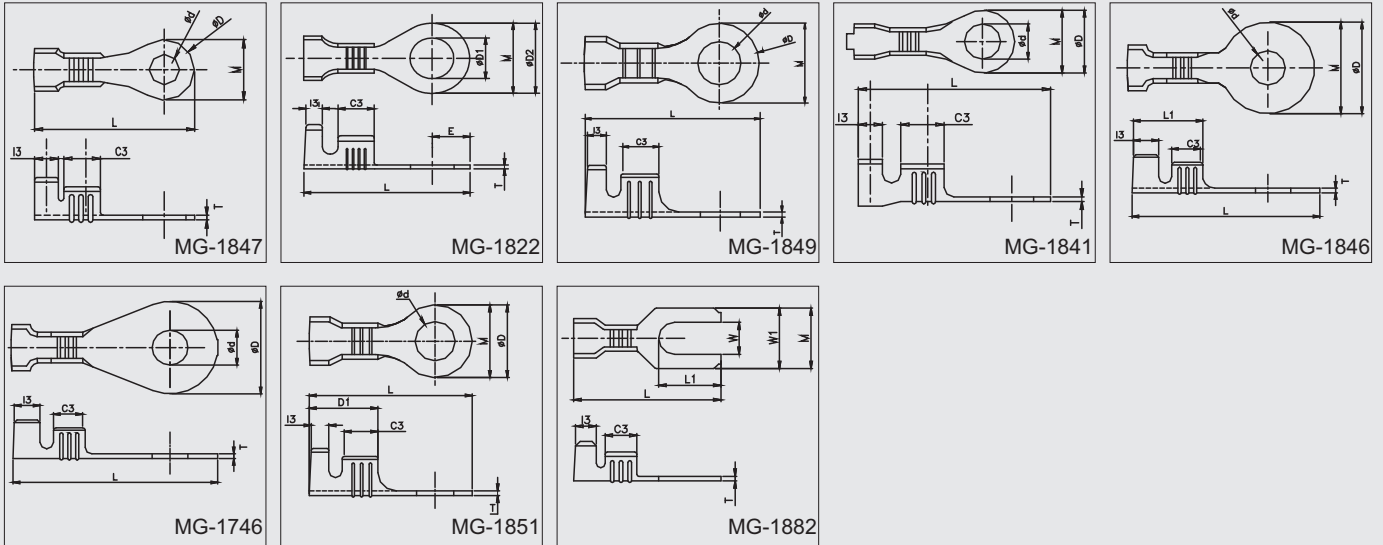

RING & FORK - A



MG CAT No.	TAB Size mm	Cable Size mm ²	Description	L	H	W	APPLICABLE MATING TERMINAL	MATERIAL	"STD PACKING QTY.(NOS) CHAIN"
MG-1847	4.3	0.5 - 1.5	Ring Terminal 4.3 ID	17.0	0.5	6.6	NA	BRASS	8,000
MG-1822	5.4	0.75 - 1.5	Ring Terminal 5.4 ID	21.5	0.5	9.5	NA	BRASS	6,000
MG-1849	8.2	0.5 - 1.5	Ring Terminal 8.2 ID	24.0	0.6	12.0	NA	BRASS	4,000
MG-1841	4.2	0.5 - 1.5	Ring Terminal 4.2 ID	20.0	0.5	18.0	NA	BRASS	6,000
MG-1846	6.4	0.75 - 1.5	Ring Terminal 6.4 ID	24.0	0.5	12.0	NA	BRASS	4,000
MG-1746	6.4	0.5 - 1.0	1846 Small Conical	24.0	0.6	12.0	NA	BRASS	4,000
MG-1851	6.4	2.0 - 4.0	Ring Terminal 6.4 ID	26.5	0.6	12.0	NA	BRASS	2,000
MG-1882	NA	0.75 - 1.5	Fork Terminal Straight	16.8	0.5	7.0	NA	BRASS	4,000

*All dimensions in mm

WE CONNECT ENERGY

www.mgelectrica.com

F-41, MIDC Area, Satpur, Nasik-7, Maharashtra, India. Telfax: +91 253 2350961, 2350163 lugs@mgelectrica.com

For details about our other products and specifications please refer the corporate website

Disclaimer: M.G reserve the right product without prior, as part of its continual improvement programme. Whilst every effort is taken to ensure the accuracy of information contained in the sheet, M.G accepts no liability for matters arising as result of errors or omissions.